

Model 3050-SLR for Super Low Range Moisture Analysis

Quartz-crystal Microbalance Technology: Accurate. Reliable. Verifiable. Response.

Welcome to the New World of Process Moisture Analysis

The Model 3050-SLR provides extremely accurate measurement of trace levels of moisture in a gas through the use of a quartz-crystal oscillator sample cell. AMETEK is the leader in quartz-crystal technology which, for thirty years has offered significant advantages over other measurement techniques:

- || It is the most accurate trace moisture measurement technology available.
- || It responds far faster to both increasing and decreasing moisture levels.
- || It is specific to moisture in most applications.
- || It provides a much more rugged sensor.

Because of these advantages, the quartz-crystal oscillator has

become the industry standard for applications ranging from ultrahigh purity semiconductor gases to natural gas streams containing 30% H₂S. Now the 3050-SLR brings the benefits of quartz-crystal technology to a broad spectrum of low-range moisture measurement applications.

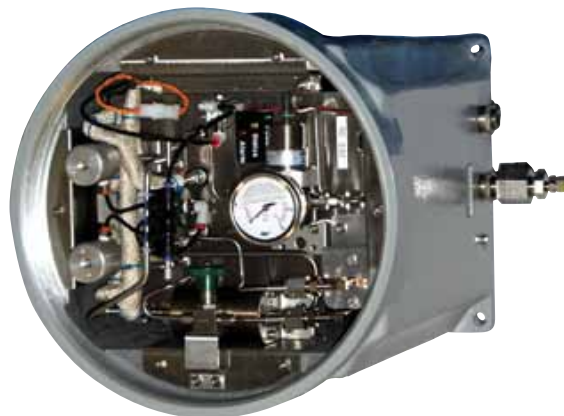

Model 3050-SLR for Super Low Range Moisture Analysis.

Direct Measurement of Concentration

The Model 3050-SLR measures moisture concentration directly in parts-per-million by volume, parts-per-million by weight, or mass-of-water per standard volume without additional pressure or temperature compensation. For customers who wish to convert concentration to dew/frost point, the 3050-SLR can be programmed for a live process pressure input or a fixed process pressure.

Accurate and Responsive

The accuracy of the 3050-SLR is an amazing ± 0.03 ppmv or $\pm 10\%$ of reading, whichever is greater, over the calibrated range of 0.1 to 2500 ppmv. Compare this to the typical accuracy of a hygrometer.

ACTUAL PPMV MOISTURE	MODEL 3050-SLR ACCURACY	ALUMINUM-OXIDE ACCURACY <small>$\pm 2^{\circ}$ C FOR DEW POINTS $\geq -65^{\circ}$ C AND $\pm 3^{\circ}$ C FOR BELOW</small>
0.1	± 0.03 ppmv	+72%/-43% of reading
1	$\pm 10\%$ of reading	+59.6%/-38.2% of reading
5	$\pm 10\%$ of reading	+52.4%/-35.2% of reading
10	$\pm 10\%$ of reading	+30.9%/-24.0% of reading
20	$\pm 10\%$ of reading	+29.3%/-23.0% of reading

Dew point conversions are referenced to 14.7 psia.

The design of the 3050-SLR enables a speed of response that is far superior to other analyzers while consuming as little as 150 sccm of sample gas. The reliability and stability of the QCM sensor completely eliminates the need for routine factory recalibration requirements. Your confidence in the analyzer's performance is assured because every 3050-SLR has the ability to self-verify the QCM sensor's responsiveness to moisture changes.

On-line Verification Ability

The 3050-SLR is equipped with the ability to self-verify its accuracy and sensitivity to moisture. With a built-in zero module and internal moisture generator, the 3050-SLR gives you data you will have confidence in. On a programmed schedule or whenever you feel it's necessary, you can route your process gas through the 3050-SLR's internal zero gas generator and its internal moisture generator, giving you a zero reference and a span calibration standard based

upon the actual process gas. The 3050-SLR automatically zeroes itself then compares its moisture measurement with the NIST-traceable known value of the internal moisture generator. If necessary, the analyzer can make small corrections to its calibration automatically. If a severe calibration problem exists, the analyzer will provide an alarm. With the 3050-SLR, you will always be confident that the analyzer is responsive to the moisture present in the sample gas.



The Quartz-Crystal Sensor

The heart of the 3050-SLR analyzer is a quartz-crystal microbalance (QCM) sensor and sampling system developed by AMETEK specifically for highly accurate moisture measurements. The sensor consists of a quartz-crystal disc coated with a hygroscopic polymer. As the amount of moisture sorbed onto the polymer varies, the mass of the QCM changes producing a corresponding change in the frequency of oscillation.

Additional Sample System Components

In order to derive the full advantages of the Model 3050-SLR, a well-designed sampling system is necessary. AMETEK can supply a complete sampling system to include:

- || **Filters:** In-line or bypass filters to remove particulate from gas or liquid sample streams and small amounts of oil or other condensables from gas streams.
- || **Pressure Reducer:** Required if sample sources are at pressures higher than 3.45 Bar (50 psi). Maximum input pressure is 200 Bar (3000 psi).
- || **Heated Pressure Reducer:** Designed to prevent condensation of gases upon pressure reduction or to vaporize liquefied gas streams with boiling points not exceeding 40° C (104° F). Maximum input pressure is 200 Bar (3000 psi). Suitable for NEC/CEC Class I, Division 1, Groups B/C/D, and CENELEC IIC T3 areas.

Process Gas Cycle

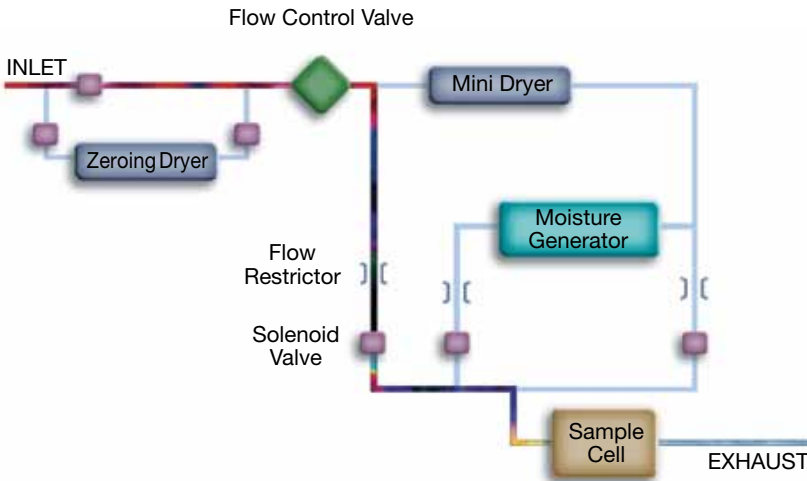

Reference Gas Cycle

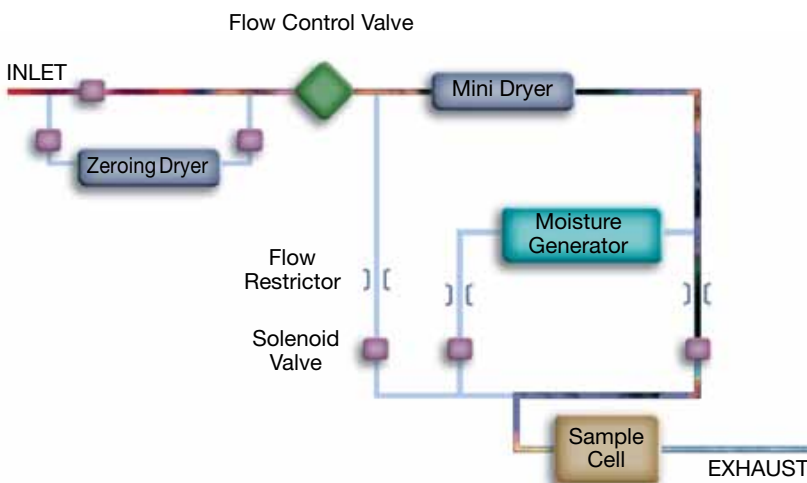

Non-Equilibrium Operating Theory of Quartz-Crystal Microbalance

Moisture sensors are notoriously slow because they need a long time to equilibrate, especially when drying down. Non-equilibrium operation is a special technique developed as a means of improving a moisture sensor's speed of response. It works by systematically cycling the sensor between the process gas and a dry reference gas.

During the process gas cycle (top, left), moisture molecules accumulate on the surface of the QCM sensor. During the reference gas cycle (bottom, left), these water molecules are swept off the surface of the sensor by the dry gas flow. Since there is no waiting for equilibrium, the system provides a measurement of moisture concentration every cycle.

The number of water molecules that accumulate on the surface of the sensor is a function of the difference in moisture between the process gas and reference gas. The analyzer compares the process gas with the known, dry reference as opposed to trying to measure an absolute value that only occurs once the equilibrium has been achieved. When a high moisture event occurs, the 3050-SLR responds quickly to alert you to the problem. After the high moisture event passes, the non-equilibrium nature of the Model 3050-SLR means that no long dry down period is ever needed before you will get accurate sub-ppmv measurements.

Model 3050-SLR for Super Low Range Moisture Analysis

MOISTURE

Performance Specifications

Technology: Quartz-Crystal Microbalance

Range: 0.1 to 100 parts-per-million by volume (ppmv). Readout capability in ppmw, lb/mmscf, mg/Nm³, and dew point in °F or °C (requires process pressure as an input)

Reference Gas: Continuously produced using actual sample gas

On-Line Verification: Internal moisture source with NIST-traceable calibration enables on-demand verification of analyzer accuracy and responsiveness without uninstalling the analyzer. Verification function can be triggered remotely with a voltage signal.

Accuracy: ±0.03 ppmv or ±10% of reading from 0.1 to 2500 ppmv whichever is greater

Reproducibility: ±0.015 ppm or ±5.0% of reading whichever is greater

Limits of Detection: 0.1 ppmv

Moisture Generator: 1.0 ppmv nominal, calibration is NIST-traceable

Reliability: No routine factory calibration required due to highly stable and reliable nature of QCM sensor

QCM Response Time: Near real time. Computer-enhanced response, which may lead to errors, is not required to obtain quick wet-up or dry-down response.

Sensitivity: 0.01 ppmv or 1% of reading, whichever is greater

Allowable Inlet Pressure: 1.38 to 3.45 Bar (20 to 50 psi) gauge (up to 200 Bar [3000 psi]) with optional pressure reducer; analyzer performance is independent of process pressure

Exhaust Pressure: 0 to 1 Bar (0 to 15 psi)

Sample Gas Temperature: 0° to 100°C (32° to 212°F); analyzer performance is immune to changes in sample gas temperature

Gas Flow Requirements: Approx. 150 sccm. Approx. 1.0 slpm bypass flow for increased speed of response

Alarms: Two contact closures: system and data valid alarms

Outputs: Isolated 4 to 20 mA analog signal, keyboard selectable; 12 bit (0.025%) resolution, RS-232 and RS-485 serial communication ports (supports Modbus RTU)

Ambient Temperature Limits: -20° to 45° C (-4° to 113° F)

Utility Requirements
120/240 VAC, 50/60 Hz, 150 Watts
Instrument Air: 70 to 100 psi (5 to 7 Bar)

Approvals and Certifications
UL/CSA General Safety Requirements
UL/CSA Class I, Division 1, Groups B, C, D T6

Electromagnetic Compatibility Directive; EN61326-1 Industrial Low Voltage Directive; EN61010-1 Pressure Equipment Directive
ATEX Directive: II 2 G Ex de IIC T6 (or T5) Gb IP65

The T6 rating applies to ambient temperatures below 40°C
Russian Gosstandart Pattern Approval
Russian Ex Proof Certification: 1ExdIICT6X

Enclosure
IP65

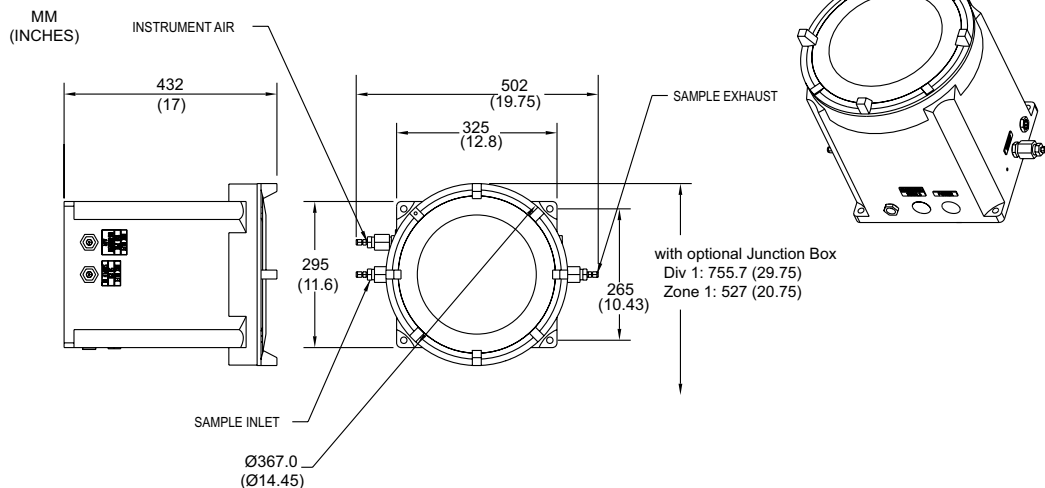

455 Corporate Blvd., Newark, DE 19702
Ph. +1-302-456-4400, Fax +1-302-456-4444
www.ametekpi.com



© 2014, by AMETEK, Inc.
All rights reserved. Printed in the U.S.A.
F-0126 Rev 6 (0214)

One of a family of innovative process analyzer solutions from AMETEK Process Instruments.
Specifications subject to change without notice.

SALES, SERVICE AND MANUFACTURING:

USA - Pennsylvania
150 Freeport Road, Pittsburgh PA 15238 • Tel: +1-412-828-9040, Fax: +1-412-826-0399

USA - Delaware
455 Corporate Blvd., Newark DE 19702 • Tel: +1-302-456-4400, Fax: +1-302-456-4444

Canada - Alberta
2876 Sunridge Way N.E., Calgary AB T1Y 7H2 • Tel: +1-403-235-8400, Fax: +1-403-248-3550

WORLDWIDE SALES AND SERVICE LOCATIONS:

USA - Houston, Texas
Tel: +1-713-466-4900, Fax: +1-713-849-1924

BRAZIL
Tel: +55 19 2107 4100

CHINA
Beijing / Tel: +86 10 8526 2111, Fax: +86 10 8526 2141
Chengdu / Tel: +86 28 8675 8111, Fax: +86 28-8675 8141
Shanghai / Tel: +86 21 6426 8111, Fax: +86 21 6426 7818

USA - Austin, Texas
Tel: +1-512-252-2440, Fax: +515-252-2430

FRANCE
Tel: +33 1 30 68 89 20, Fax: +33 1 30 68 89 99

GERMANY
Tel: +49 21 59 91 36 0, Fax: +49 21 59 91 3639

INDIA
Tel: +91 80 6782 3200, Fax: +91 80 6782 3232

SINGAPORE
Tel: +65 6484 2388, Fax: +65 6481 6588