

## Model 3050-DO for Dryer Outlet Monitoring

Reduce operational costs and increase plant uptime through feedback control

Tremendous cost savings can be realized through optimization of mole sieve dryer operation. Use of a truly accurate and reliable moisture analyzer enables feedback control of dryer regeneration. Feedback control minimizes the frequency of bed regeneration resulting in lower operational costs and extended plant uptime. AMETEK Process Instruments has designed the Model 3050-DO to specifically monitor the very low moisture levels typically exiting mole sieve dryer systems.

The Model 3050-DO provides extremely accurate measurement of trace levels of moisture in a gas through the use of a quartz-crystal oscillator sample cell. AMETEK is the leader in quartz-crystal technology, which for thirty years has offered significant advantages over other measurement techniques:

- || It is the most accurate trace moisture measurement technology available.
- || It responds far faster to both increasing and decreasing moisture levels.
- || It is specific to moisture in most applications.
- || It provides a much more rugged sensor.

Today, because of these advantages, quartz-crystal-based moisture analyzers are the fastest growing line of moisture analyzers in the world.



Model 3050-DO for Dryer Outlet Monitoring

### Quartz-Crystal Microbalance – The Safest Choice

#### *Dramatically Better Accuracy*

Consider the basic accuracy specification of the 3050-DO:  $\pm 0.02$  ppmv or  $\pm 10\%$  of reading, whichever is greater, over the operating range of 0.02 to 2500 ppmv. In the table on the following page, we've compared this to the accuracy of a humidity analyzer that is typically listed as dew point. The typical specification is  $\pm 3^{\circ}\text{C}$  dew point for gases drier than  $-65^{\circ}\text{C}$  dew point. The data for the aluminum-oxide analyzer is based upon the specifications of a newly calibrated probe. The aluminum oxide's calibration drift, temperature instability and other sources of error are not typically taken into account by the

probe manufacturer's accuracy specification. The aluminum oxide's slow speed of response is another issue.

#### *Direct Measurement of Concentration*

The Model 3050-DO measures moisture concentration directly in parts-per-million by volume, parts-per-million by weight, or mass-of-water per standard volume without additional pressure or temperature compensation. This provides you with a direct, meaningful reference to benchmark your dryer's performance. For customers who wish to convert concentration to dew point, the 3050-DO can be programmed with the process pressure.

**Long Term Stability Reduces Maintenance Costs**

The 3050-DO analyzer is inherently more stable due to its quartz-crystal microbalance technology. The stability of the vibrating quartz crystal means that you never need to send the analyzer out for re-calibration. This means that you will forever eliminate those costly, routine maintenance projects that are associated with aluminum-oxide humidity sensors. But don't take our word about the analyzer's stability; ask the analyzer itself! Every 3050-DO comes equipped with an internal verification system that consists of both zero and span challenges that are created from the actual sample gas.

**Built-in Verification Capability**

With the built-in zero module and the internal moisture generator, the 3050-DO gives you data you can have confidence in. On a programmed schedule or whenever you feel it's necessary, you can route your process gas through the 3050-DO's internal zero gas generator and its internal moisture generator, giving you a zero reference and a span calibration standard based upon the actual process gas. The 3050-DO automatically zeroes itself and compares its moisture measurement with the NIST-traceable known value of the internal moisture generator. If

ACTUAL PPMV MOISTURE	MODEL 3050-DO Accuracy	ALUMINUM-OXIDE ACCURACY ±2° C FOR DEW POINTS ≥ -65° C AND ±3° C FOR BELOW
0.1	±0.02 ppmv	+72.0%/-57.0% of reading
1	±10% of reading	+59.6%/-38.2% of reading
5	±10% of reading	+52.4%/-35.2% of reading
10	±10% of reading	+30.9%/-24.0% of reading
20	±10% of reading	+29.3%/-23.0% of reading

\* Dew point conversions are referenced to 14.7 psia

necessary, the analyzer can make small corrections to its calibration automatically. If a severe calibration problem exists, the analyzer will provide an alarm. With the 3050-DO, you will always be confident that the analyzer is responsive to the moisture present in the sample gas.

**Gain Peace of Mind Through Active Feedback**

The Model 3050-DO is an active device. It is constantly monitoring itself for its frequency of oscillation, sample flow, sample pressure, operating temperature, ambient temperature, and other telling parameters. In addition, the QCM sensor is continually challenged with

increasing and decreasing moisture levels due to the non-equilibrium nature of its operation. Through this continuous system of active feedback, the 3050-DO keeps you confident in its performance. Remember, if at any time you doubt the analyzer's readings, you can use the built-in verification function.

The 3050-DO is simply the best analyzer available for controlling and optimizing your gas drying process. Make the decision to protect your process, your revenue, and your peace of mind today.

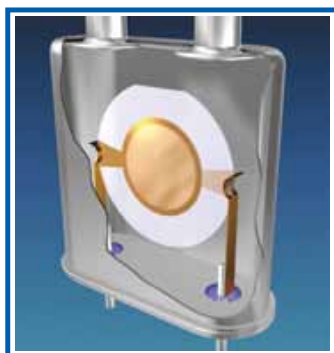

**The Quartz-Crystal Sensor**

The heart of the 3050-DO analyzer is a quartz-crystal microbalance (QCM) sensor and sampling system developed by AMETEK specifically for highly accurate moisture measurements. The sensor consists of a pair of electrodes that support the QCM sensor. When voltage is applied to the sensor, a very stable oscillation occurs.

The faces of the oscillator are covered with a hygroscopic polymer. As the amount of moisture sorbed on to the polymer varies, the mass of the QCM changes producing a corresponding change in the frequency of oscillation. This change is directly related to the surrounding gas.

### Process Gas Cycle

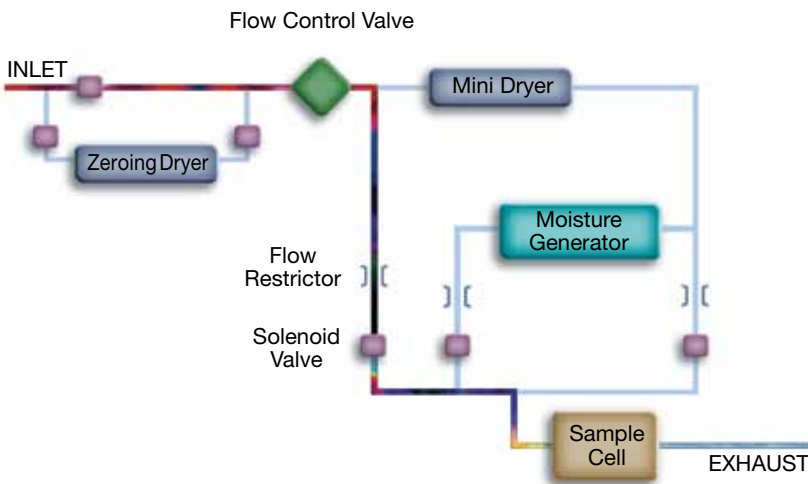

### Reference Gas Cycle

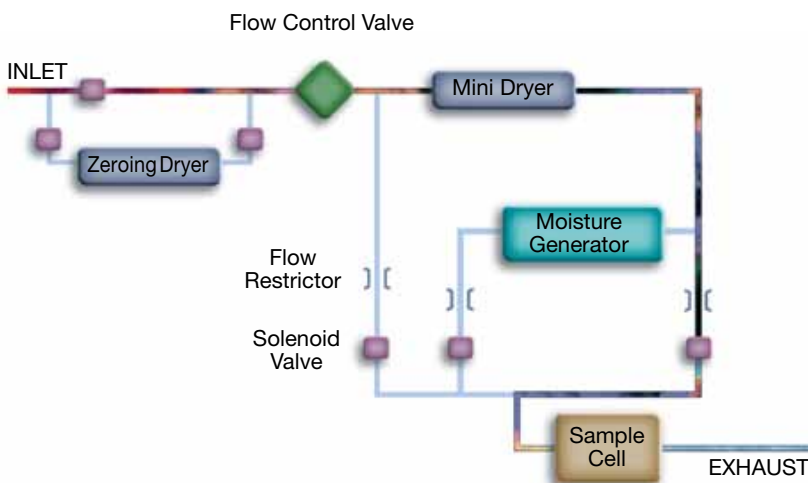

## Non-Equilibrium Operating Theory of Quartz-Crystal Microbalance

Moisture sensors are notoriously slow because they need a long time to equilibrate, especially when drying down. Non-equilibrium operation is a special technique developed as a means of improving a moisture sensor's speed of response. It works by systematically cycling the sensor between the process gas and a dry reference gas.

During the process gas cycle (top, left), moisture molecules accumulate on the surface of the QCM sensor. During the reference gas cycle (bottom, left), these water molecules are swept off the surface of the sensor by the dry gas flow. Since there is no waiting for equilibrium, the system provides a measurement of moisture concentration every cycle.

The number of water molecules that accumulate on the surface of the sensor is a function of the difference in moisture between the process gas and reference gas. The analyzer compares the process gas with the known, dry reference as opposed to trying to measure an absolute value that only occurs once the equilibrium has been achieved. When a high moisture event occurs, the 3050-DO responds quickly to alert you to the problem. After the high moisture event passes, the non-equilibrium nature of the 3050-DO means that no long dry down period is ever needed before you will get accurate sub-ppmv measurements.

# Model 3050-DO for Dryer Outlet Monitoring

MOISTURE

## Performance Specifications

**Technology:** Quartz-Crystal Microbalance

**Range:** 0.02 to 2500 parts-per-million by volume (ppmv). Readout capability in ppmw, lb/mmscf, mg/Nm<sup>3</sup>, and dew point in °F or °C (requires process pressure as an input).

**Limit of Detection:** 0.02 ppmv

**Accuracy:** ±0.02 ppmv or ±10% of reading from 0.02 to 2500 ppmv whichever is greater

**QCM Response Time:** Near real time. Computer-enhanced response, which may lead to errors, is not required to obtain quick wet-up or dry-down response.

**Allowable Inlet Pressure:** 1.38 to 3.45 Bar (20 to 50 psi) [up to 200 Bar (3000 psi) with optional pressure reducer]; analyzer performance is independent of process pressure

**Exhaust Pressure:** 0 to 1 Bar (0 to 15 psi)

**Gas Flow Requirements:**  
Approximately 150 sccm.  
Approximately 1.0 slpm bypass flow for increased speed of response

**Sample Gas Temperature:** 0° to 100° C (32° to 212° F); analyzer performance is immune to changes in sample gas temperature

**Outputs:** Isolated 4 to 20 mA analog signal, keyboard selectable; 12 bit (0.025%) resolution, RS-232 and RS-485 serial communication ports (supports Modbus RTU)

**Alarms:** Two contact closures; system and data valid alarms

**Ambient Temperature Limits:** -20° to 45° C (-4° to 113° F)

### Utility Requirements

120/240 VAC, 50/60 Hz, 150 Watts  
Instrument Air: 5 to 7 Bar (70 to 100 psi)

**Reference Gas:** Continuously produced using actual sample gas

**On-Line Verification:** Internal zero gas generator plus an internal moisture source with NIST-traceable calibration. These systems enable on-demand verification of analyzer accuracy and responsiveness without uninstalling the analyzer. Verification function can be triggered remotely with a voltage signal.

**Reproducibility:** ±5.0% of reading from 0.2 to 2500 ppmv

**Moisture Generator:** 1.0 ppmv nominal; calibration is NIST-traceable

**Reliability:** No routine factory calibration required due to highly stable and reliable nature of QCM sensor

**Sensitivity:** 0.01 ppmv or 1% of reading, whichever is greater

**Weather Protection:** System is suitable for outdoor installation. Enclosure is non-metallic and corrosion-resistant.

**Dimensions: (W x H x D):**  
67.1 x 67.2 x 33.9 cm  
(26.4 x 26.5 x 13.34 in.)

### Approvals and Certifications

UL/CSA General Safety Requirements

UL/CSA Class I, Division 2, Groups ABCD T4

Complies with all relevant European Directives

Russian Gosstandart Pattern Approval

## Additional Sample System Components

In order to derive the full advantages of the Model 3050-DO, a well-designed sample transport system is necessary. AMETEK can supply a complete sampling system to include:

- || **Filters:** In-line or bypass filters to remove particulate from gas or liquid sample streams and small amounts of oil or other condensables from gas streams.
- || **Pressure Reducer:** Required if sample sources are at pressures higher than 3.45 Bar (50 psi). Maximum input pressure is 200 Bar (3000 psi).
- || **Heated Pressure Reducer:** Designed to prevent condensation of gases upon pressure reduction, or to vaporize liquefied gas streams with boiling points not exceeding 40° C (104° F). Maximum input pressure is 200 Bar (3000 psi). Suitable for NEC/CEC Class I, Division 1, Groups B/C/D, and CENELEC IIC T3 areas.



455 Corporate Blvd., Newark, DE 19702  
Ph. +1-302-456-4400, Fax +1-302-456-4444  
www.ametekpi.com



© 2014, by AMETEK, Inc.  
All rights reserved. Printed in the U.S.A.  
F-0123 Rev 5 (0314)

One of a family of innovative process analyzer solutions from AMETEK Process Instruments.  
Specifications subject to change without notice.

### SALES, SERVICE AND MANUFACTURING:

**USA - Pennsylvania**  
150 Freeport Road, Pittsburgh PA 15238 • Tel: +1-412-828-9040, Fax: +1-412-826-0399

**USA - Delaware**  
455 Corporate Blvd., Newark DE 19702 • Tel: +1-302-456-4400, Fax: +1-302-456-4444

**Canada - Alberta**  
2876 Sunridge Way N.E., Calgary AB T1Y 7H2 • Tel: +1-403-235-8400, Fax: +1-403-248-3550

### WORLDWIDE SALES AND SERVICE LOCATIONS:

**USA - Houston, Texas**  
Tel: +1-713-466-4900, Fax: +1-713-849-1924

**BRAZIL**  
Tel: +55 19 2107 4100

**CHINA**  
Beijing / Tel: +86 10 8526 2111, Fax: +86 10 8526 2141  
Chengdu / Tel: +86 28 8675 8111, Fax: +86 28-8675 8141  
Shanghai / Tel: +86 21 6426 8111, Fax: +86 21 6426 7818

**USA - Austin, Texas**  
Tel: +1-512-252-2440, Fax: +515-252-2430

**FRANCE**  
Tel: +33 1 30 68 89 20, Fax: +33 1 30 68 89 99

**GERMANY**  
Tel: +49 21 59 91 36 0, Fax: +49 21 59 91 3639

**INDIA**  
Tel: +91 80 6782 3200, Fax: +91 80 6782 3232

**SINGAPORE**  
Tel: +65 6484 2388, Fax: +65 6481 6588