

PREMIX 2000 AIR/FUEL RATIO ANALYZER FOR PREMIX BURNERS

Permanent installation sensor for control of fiberizing lines and other precombustion applications.

The Thermox PreMix 2000 analyzer accurately and continuously measures the proportions of oxygen and fuel in pre-mix gases, operating in either excess fuel or excess air conditions. The analyzer is fed a small sample of the air/fuel mixture, burns it and then measures the net oxygen or net excess fuel content of the mixture.

The PreMix 2000 uses the Series 2000 Control Unit. This state-of-the-art microprocessor control unit provides software-selectable calibration options, and extensive analog and digital I/O capabilities, including a bi-directional RS-485 communications port. It also employs a modular design that makes adding future upgrades or servicing easy.



OPERATION

Most of the sample gas entering the analyzer passes through the bypass flow meter, which ensures a fast response and keeps the sample inlet purged of dead volume. A small portion of the sample flows through the sample flow meter and flashback arrestor to the furnace. An igniter at the inlet of the furnace enables the fuel mixture to burn. The products of combustion then flow past the zirconium oxide cell, where they are measured.

APPLICATIONS

- ▶ Glass forehearth
- ▶ Air/fuel mixtures
- ▶ Glass fiber apparatus
- ▶ Open flame brazing and soldering
- ▶ Tempering furnaces
- ▶ Gas generators
- ▶ Metals and metal forming

FEATURES/BENEFITS

- ▶ Measure air/fuel ratio in open-flame applications where flue gas measurements are not practical.
- ▶ Measurement and display options include excess oxygen, excess fuel, combined excess oxygen to excess fuel, fuels/oxides, oxides/fuels, and combustibles.
- ▶ Operates under either excess air (lean) or excess fuel (rich) conditions.
- ▶ Calculates calibration gas mixture concentration for excess fuel ranges.

SENSOR

Range: All or selected portions of the range from 100% to 0.1% excess oxygen and 0.1% to 50% Excess Fuel

Accuracy: ± 2% of measured value or ±0.1% O₂, whichever is greater; ± 5% of measured value or .25% excess fuel, whichever is greater*.

Repeatability: ± 0.2% of measured value

Ambient Temperature: -5 to 158°F (-20 to 70°C)

Sample Flow Rate: 0.5 L/min. (1 scfh)

Bypass Flow Rate: - 50 L/min. max. (106 scfh)

Max. Sample Pressure: 10 psig

Power: 115 VAC ± 10%, 50/60 Hz., 1200 VA max.; 230 VAC ± 10%, 50/60 Hz., 2400 VA max.

Calibration Gas Flow Rate: 10 psig, 2.1 to 4.2 scfh (0.70 kg/cm², 1.0 to 2.0 L/min.)

Excess Oxygen Calibration Gases:

O₂ Span Gas: 20.9% (air) or from 1.0 to 100% O₂, balance N₂

O₂ Zero Gas: 2% or from 0.1% to 10% O₂, balance N₂

Excess Fuel Calibration Gases:

CH₄/O₂/N₂ Span: 40 to 60% of recorder output span

CH₄/O₂/N₂ Zero: 5 to 10% of recorder output span

Enclosure: UL Type 3R (IP14)

* Specifications based on 0-15% range, Natural Gas

PREMIX 2000 ANALYZER

CONTROL UNIT

Display: Four-line x 20-character vacuum fluorescent. Displays combinations of excess oxygen, excess fuel, combined oxygen to excess fuel range, fuel/oxides, oxides/fuel, combustibles, time and date, cell temperature, user programmable text, thermocouple mV, or cell mV. Password protection and context-sensitive help are provided.

Analog Output: Two isolated linear current outputs. Select excess oxygen, excess fuel, combined excess oxygen to excess fuel range, combustibles, fuel/oxides, oxides/fuel, cell temperature, thermocouple mV or cell mV. Each output can be 4-20 mA, 0-20 mA, 20-4 mA or 20-0 mA and is fully scalable. Hold or track during calibration and select degree of damping. Maximum load 1200 ohms.

Alarms: Two independent alarms, each high or low selectable. One alarm can be allocated to sensor readings, calibrate or verify. Set relays to energize or de-energize on alarm.

Contact Rating: 0.5A, 30V, 10VA max. noninductive load, AC or DC

Diagnostics: Watchdog timer and service alarms. System test for A/D, RAM, EEPROM, and keypad. Display line 4 reserved for full text error and diagnostic messages. Twenty-entry event log.

Communications: RS-485, 2-way addressable

Environment:

Ambient Temp: 14°F to 122°F (-10°C to 50°C)

Relative Humidity: 10% to 90%, non-condensing

Enclosure: Standard weatherproof NEMA 4 (IP 56) wall/panel mount. Optional GP (General Purpose) wall mount, GP 19" rack mount, GP panel mount, or stainless steel weatherproof NEMA 4X (IP 56) wall/panel mount. All are UL Listed for NEC Class I, Division 2 areas. Purged and explosion-proof versions also available.

Calibration: Calibrate or verify calibration. Store last calibration and verification data. Selectable calibration gas run time and process recovery time.

Power Requirements: Nominal 115-230 VAC ± 10%, 47-63 Hz, 75 VA max.

System Compliance:

EMC Directive 2004/108/EC

Low Voltage Directive 73/23/EEC

AMETEK®
PROCESS INSTRUMENTS

150 Freeport Road, Pittsburgh, PA 15238
Ph. +1-412-828-9040, Fax +1-412-826-0399
www.ametekpi.com



© 2012, by AMETEK, Inc.
All rights reserved. Printed in the U.S.A.
F-0160 Rev. 4 (0114)

One of a family of innovative process analyzer solutions from AMETEK Process Instruments.
Specifications subject to change without notice.

SENSOR

APPROX. WEIGHT: 30 LB (13.6 KG)

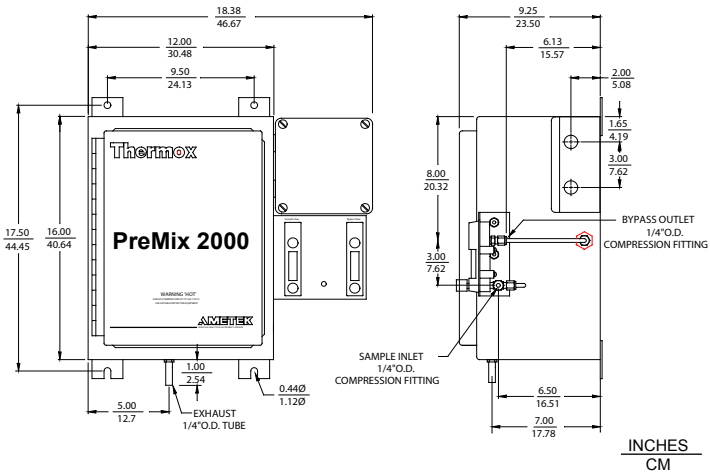

CONTROL UNIT

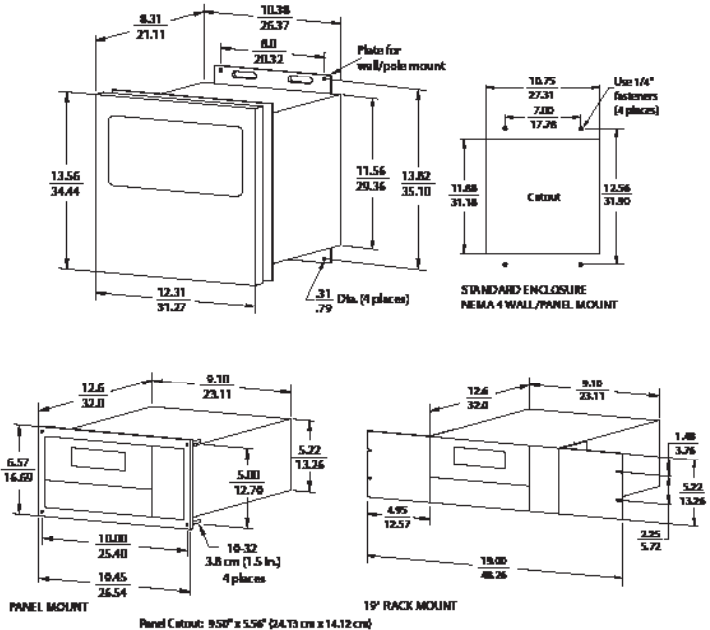

APPROX. WEIGHTS:
NEMA 4 WALL/PANEL MOUNT: 28 LB / 12.7 KG
19" RACK MOUNT: 14 LB / 6.35 KG
PANEL MOUNT: 14 LB / 6.35 KG

NOTES:

1. All static performance characteristics are with operating variables constant.
2. System accuracy referenced to 0.1 to 10% calibrated range.
3. Response is to calibration gas.

SALES AND MANUFACTURING:

Canada - Alberta
2876 Sunridge Way N.E., Calgary AB T1Y 7H2 • Tel: +1-403-235-8400, Fax: +1-403-248-3550

USA - Delaware
455 Corporate Blvd., Newark DE 19702 • Tel: +1-302-456-4400, Fax: +1-302-456-4444

WORLDWIDE SALES AND SERVICE LOCATIONS:

USA - Texas
Tel: +1-713-466-4900, Fax: +1-713-849-1924

BRAZIL
Tel: 55 19 2107 4100

CHINA
Beijing / Tel: 86 10 8526 2111, Fax: 86 10 8526 2141
Chengdu / Tel: 86 28 8675 8111, Fax: 86 28-8675 8141
Shanghai / Tel: 86 21 6426 8111, Fax: 86 21 6426 7818

FRANCE
Tel: 33 1 30 68 89 20, Fax: 33 1 30 68 89 99

GERMANY
Tel: 49 21 59 91 36 0, Fax: 49 21 59 91 3639

INDIA
Tel: 91 80 6782 3200, Fax: 91 80 6782 3232

SINGAPORE
Tel: 65 6484 2388, Fax: 65 6481 6588

THE
RMOX®